

LKS-902SE/1102SE/1102SE-1 Leotronic

Elettropompe sommergibili multistadio elettroniche Leotronic submersible pump



Applicazione

- Elettropompa sommersa monoblocco adatta per pompare acqua pulita o liquidi simili all'acqua che abbiano le stesse proprietà fisico-chimiche.
- Pressurizzazione da pozzi tradizionali o da cisterne di stoccaggio e di recupero acque piovane.
- Adatta per pressurizzazione domestica e piccola irrigazione.

POMPA

- Dispositivo di controllo elettronico integrato
- Funzionamento automatico con sistema pressoflussostatico
- Corpo pompa in AISI 304
- Max temperatura liquido pompato: +35°
- Max capacità di immersione: 12mt.

MOTORE

- Avvolgimento motore in rame
- Motore dotato di protezione termica integrata
- Classe di isolamento: F
- Classe di protezione: IPX8

Application

- Can be used to transfer clean water or other liquids similar to water in physical or chemical properties
- Lifting water from traditional wells, cisterns
- Suitable for small scale irrigation systems

PUMP

- Intelligent control device inside
- Work automatically
- AISI 304 pump body
- Max. liquid temperature: +35°C
- Max. immersion depth: 12m

MOTOR

- Copper winding
- Built-in thermal protector
- Insulation class: F
- Protection class: IPX8



LKS1102SE
LKS902SE



LKS1102SE-1

Diagramma prestazioni Hydraulic Performance Curve

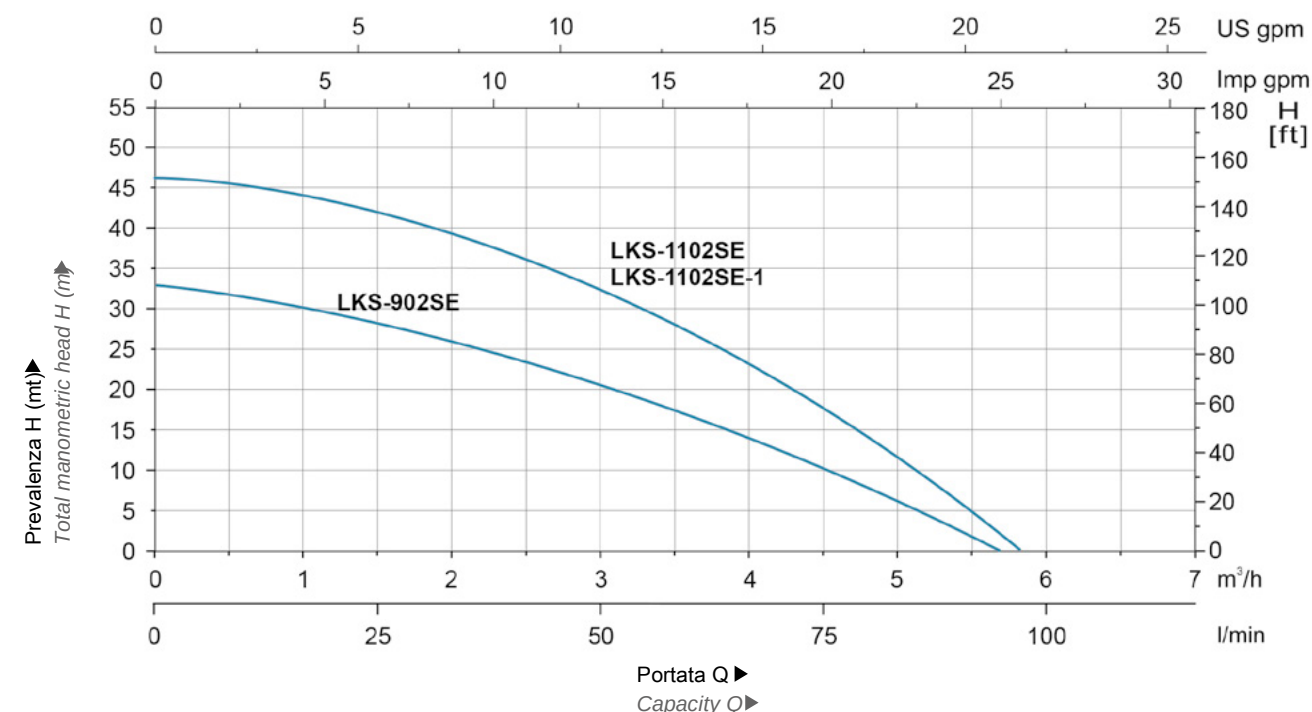

Codici identificativi

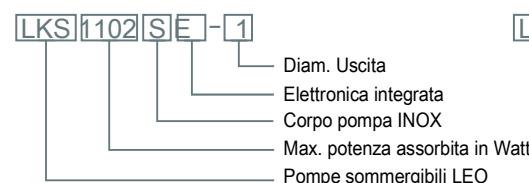

Identification Codes

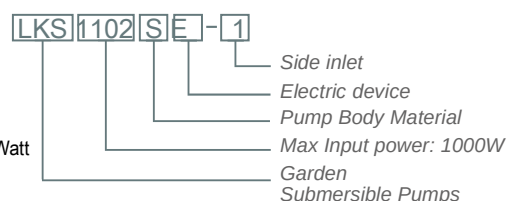

Dati tecnici | Technical Data

Modello Model	Potenza Power		Q	m³/h	H (mt)										Codice Code	
	kW	HP			0.5	1	1.5	2	2.5	3	3.5	4	4.5	5		5.5
LKS902SE	0.65	0.88			34	32	29.7	27.5	25	21.8	18	14.8	10.5	6.4	2.5	10LKS902SE
LKS1102SE	0.75	1.00			45.0	43.7	42.0	39.6	36.5	32.5	28.0	22.7	17.1	11.0	5.0	10LKS1102SE
LKS1102SE-1	0.75	1.00			45.0	43.7	42.0	39.6	36.5	32.5	28.0	22.7	17.1	11.0	5.0	10LKS1102SE-1
KIT ASPIRAZIONE																10KITLKS-1



KIT ASPIRAZIONE

Dimensioni Dimension

Modello Model	DN	L (mm)	W (mm)	H (mm)
LKS902SE		151	151	469
LKS1102SE	25	151	151	493
LKS1102SE-1		187	168	496

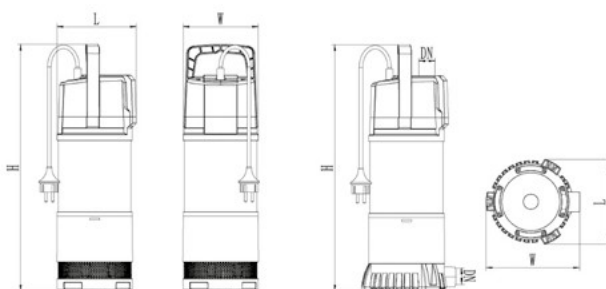

Descrizione componenti | Materials Table

Pos. Pos.	Part. Part.	Materiale Material
1	Manico Handle	PP-GF30
2	Valvola di controllo Check Valve	
3	Calotta Head Cover	PP-GF30
4	Scheda elettronica Electric Device	
5	Sensore di pressione Pressure sensor	
6	Corpo pompa Cylinder	AISI 304
7	Condensatore Capacitor	
8	Calotta superiore Upper cover	ZL102
9	Rotore Rotor	NBR
10	Cuscinetto Bearing	PP
11	Statore Stator	
12	Corteco di tenuta Framework seal	
13	Camera del cuscinetto Bearing chamber	ZL102
14	Alloggiamento Statore Stator housing	Q235
15	Support Support	PP-GF30
16	Corpo pompa Guide vane	PP-GF30
17	Tenuta meccanica Mechanical seal	
18	Girante Impeller	PPO-GF30
19	Diffusore Diffuser	PPO-GF30
20	Base Base	PP-GF30

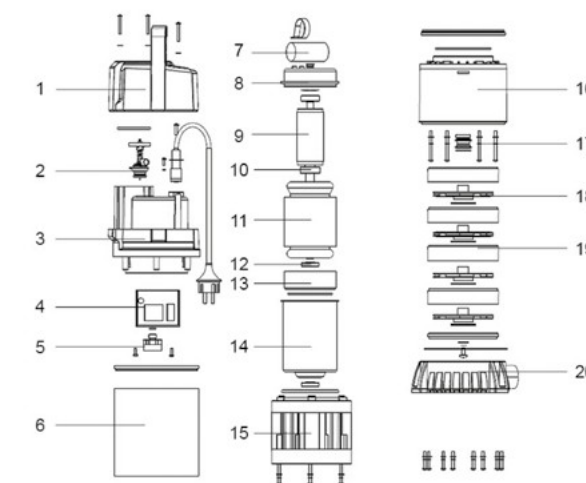

Dimensioni imballo Package information

Modello Model	GW (Kg)	L (mm)	W (mm)	H (mm)
LKS902SE	10.4	260	215	540
LKS1102SE	11.6	260	215	565
LKS1102SE-1	11.6	260	215	565

